

High Pressure Blower Specialist

THEREC ENGINEERING & CONSULTING CO.,LTD.

Air & Gas Handling System

Industrial gas & Bio gas Blower / Explosion Proof Blower

High Pressure Blower & Exhauster / Material handling Fan & Blower



DRESSER Roots
The *Original* Roots Blower
ATEX Conformity Certificate



Nota / Note:
Disponibile anche in esecuzione per
Zone 1 e 2, 21 e 22 della Direttiva Europea
94/9/CE (ATEX).
Also manufactured in conformity to the re-
quirements of the European Directive 94/9/CE
(ATEX) for zones 1 and 2, 21 and 22.



Explosive Dust Protection System

Explosion Panel / Dust explosion Flame Arrester

Explosion Isolated Valves / Rapid Fire Extinguishing Equipment



Air & Gas Boosting & Handling system

Temperature & Moisture control system

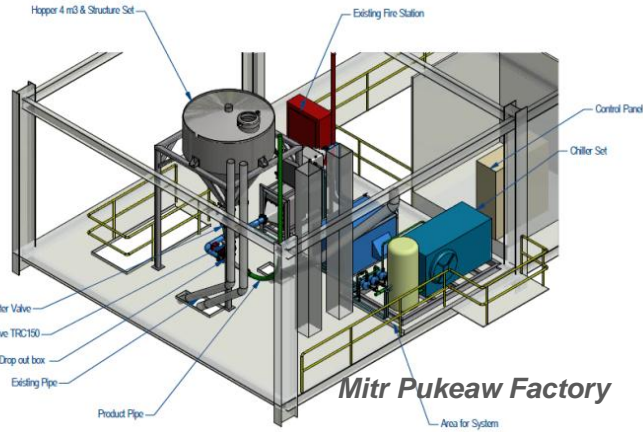
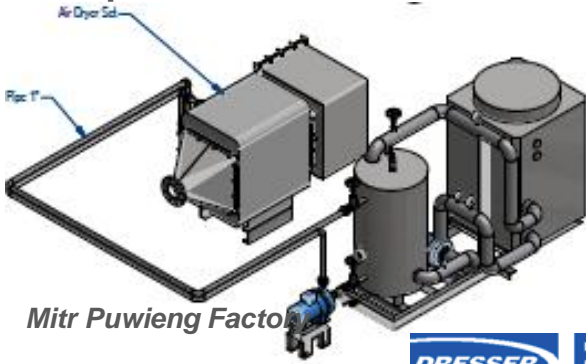

Mitr Puwieng Factory



Mitr Pukeaw Factory

Mitrphol Sugar Co., Ltd./ Sugar pneumatic conveying

Contacted conveying air moisture control to the level below 35% relative humidity to protect the sugar lump and stickiness from ambient moisture.

Contacted temperature to be under 38 degree C, to protect the internal moisture from flashing out and make the crystal to be dim.

SCADA control system with SIEMENS S7 300 series PLC



Air & Gas Boosting & Handling system

Vacuum control system

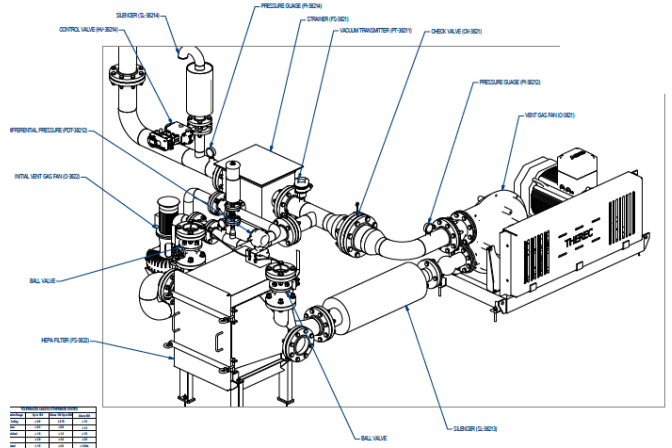
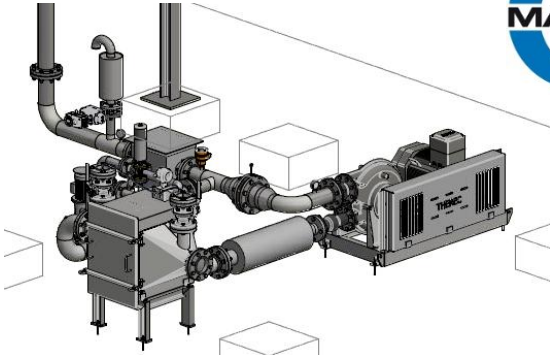

HMC Polymer Co., Ltd./ PTT Group of company, job in cooperation with CR Asia Vacuum control system for central vacuum cleaning system operation, operated by vacuum transmitter and pneumatic control valve to maintain the vacuum level of the system at -300 mBar and maintain the averaged suction air volume of each individual suction point at around 200 cfm of all working condition. Also the differential pressure switch for the filters. SCADA control system with ALAN BRADLEY 500 series PLC



Ajinomoto MFG Co., Ltd.

Basell Advanced Polyolefin Co., Ltd.

LeKise Co., Ltd.



Air & Gas Boosting & Handling system

Pressure control system

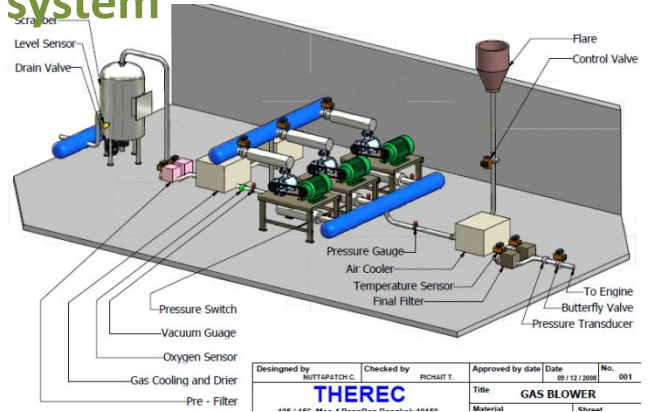
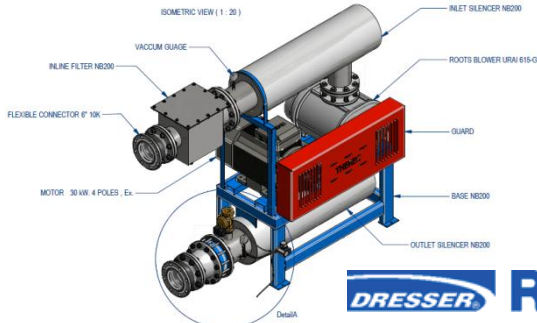

Designed by	Checked by	Approved by date	Date	No.
MUTAPATON C.	POCHAI T.		09/11/2009	001
THEREC		Title		
		GAS BLOWER		
		Material		
		1.00000		

Chareon Sompong Co., Ltd./ Underground Biogas from landfill site
 Pressure control system for bio gas boosting station / supply to gas engine of electrical generator
 By pressure transmitter and pneumatic control valve to maintain the pressure of 7 PSI supply to engine regulator and over supply gas to the flare with gas cooler and cooling tower set to maintain the feed in gas to be under 50 degree C and reduced the water content level in the biogas.
 Also with oxygen sensor/transmitter and safety vacuum switch.
 SCADA control system with SIEMENS S7 200 series PLC



Therec Engineering & Consulting Co, Ltd. www.thereceng.com
 Tel : (662) 893 9003-4 (5 lines) Fax : (662) 893 9005 ,893 9178
 88 Soi Karnjanapisek 4/2 Karnjanapisek Rd. Bangbon Bangkok 10150
 Thailand General product Therec 01 / 2016

