

THEREC ENGINEERING & CONSULTING CO.,LTD.



Big Bag Filling & Unloading Station

High Pressure Blower

Bulk Material Handling Machine & Accessories

Vacuum pump

Small bag & Tote Bin Dumping Station

Material handling fan & blower

Size reduction and classification machine

Dust explosion control equipment

Sea Bulk Loading System

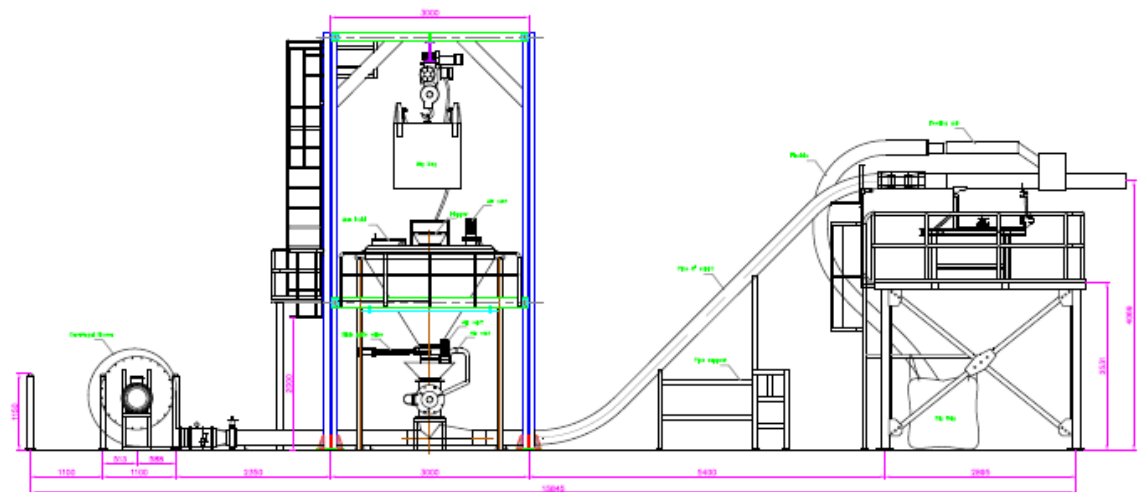

Picture from the existing line of SCG Plastic



Rotary & Diverter Valve

Stainless Steel Hopper & Silo

Lump Breaker / Lump Crusher

Stainless Steel Cyclone & Receiver

Food Grade Screw Conveyor

Stainless Fabrication Work

Therec Engineering & Consulting Co, Ltd. www.thereceng.com

Tel (662) 893 9003-4 (5 lines)

Fax : (662) 893 9005 ,893 9178

88 Soi Karnjanapisek 4/2 Karnjanapisek Rd. Bangbon Bangkok 10150 Thailand

General product Therec 01 / 2016



Therec Engineering & Consulting Co., Ltd.

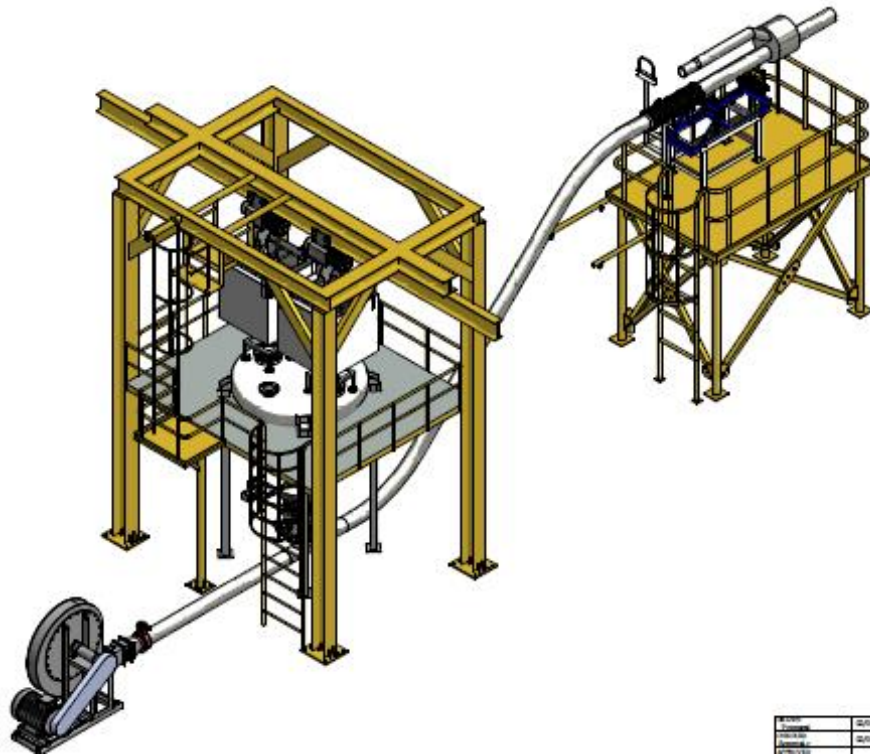

Sea Bulk loading system (PE Pellet) SCG Chem (TPE) Warehouse

The total system consisting of :

- 1 of 18.0 tons Pneumatic conveying systems
- 1 of Big bag unloading stations, 1 rail, 2 hoist operated, 3,000 litre hopper
- 1 of Fixed feeding gun for container truck, 4 directions and swing
- 1 of High pressure Centrifugal blower 18.5 kw / 25.0 hp
- 1 of Heavy duty air lock granular rotary valves (pellet valve), Stainless steel 304
- 1 of Electrical control box, with SEMENS LOGO PLC

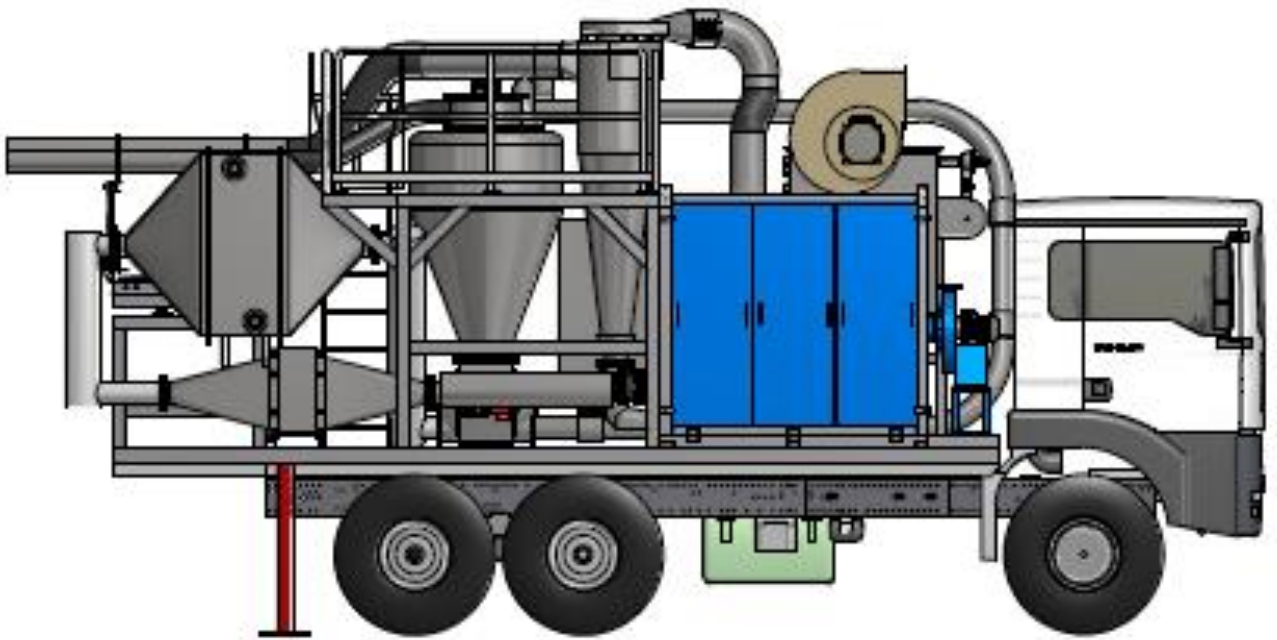

Sea Bulk loading system (PE Pellet) SCG Chem (TPC) Warehouse

The total system consisting of :

- 1 of 18.0 tons Pneumatic conveying systems
- 1 of Big bag unloading stations, 1 rail, 2 hoist operated, 3,000 litre hopper
- 1 of Fixed feeding gun for container truck, 4 directions and swing
- 1 of High pressure Centrifugal blower 18.5 kw / 25.0 hp
- 1 of Cyclone for dust controlling system, with 1,300 m³ centrifugal fan
- 1 of Bag filters for dust controlling system, with 1,300 m³ centrifugal fan
- 2 of Heavy duty air lock rotary valves (powder valve), Stainless steel 304
- 1 of Electrical control box, with SEMENS LOGO PLC

Therec Engineering & Consulting Co., Ltd.

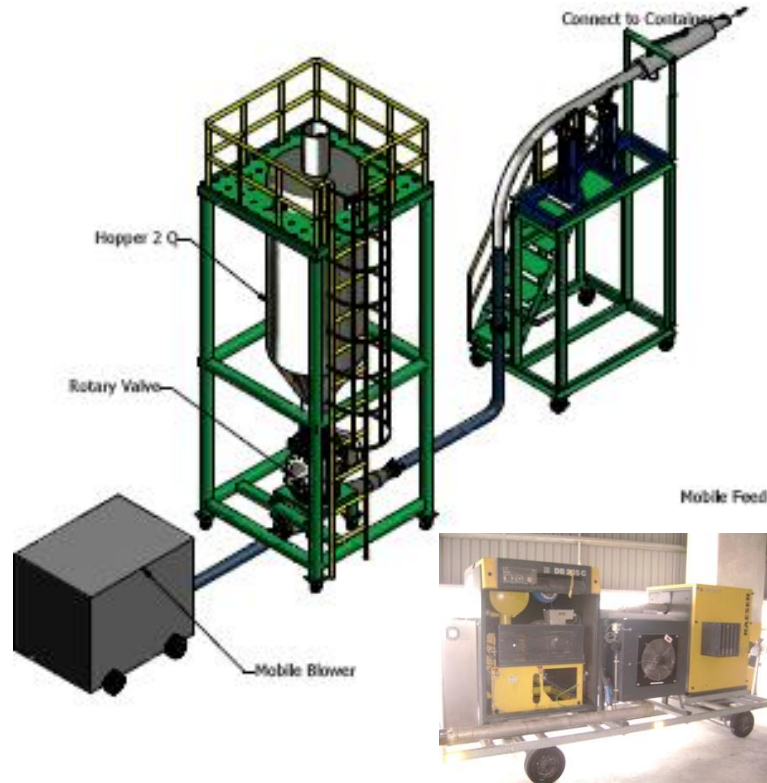

Sea Bulk loading system (PE Pellet) PTT PL Warehouse

The total system consisting of :

- 1 of 18.0 tons Pneumatic conveying systems
- 1 of Big bag unloading stations, over head crane operated, 1,500 litre hopper
- 1 of Small bag dumping stations, manual operated, 100 litre hopper
- 1 of Moveable feeding gun for container truck, 4 directions and swing
- 1 of High pressure air compressor 75.0 kw / 100.0 hp
- 2 of Heavy duty air lock rotary valves (powder valve), Stainless steel 304
- 1 of Electrical control box, with SEMENS LOGO PLC

Therec Engineering & Consulting Co., Ltd.

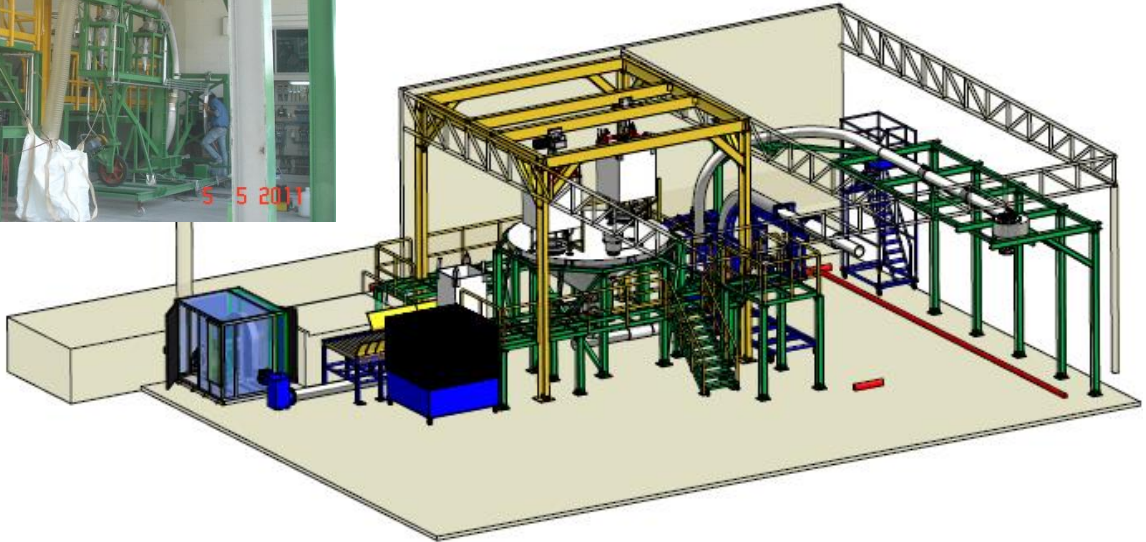

Sea Bulk loading system (PE Pellet) Ptt Global Chem Warehouse

The total system consisting of :

- 1 of 25.0 tons Pneumatic conveying systems
- 3 of Automatic roller conveyors for bulk bag feeding
- 1 of Big bag unloading stations, 2 rails, 2 hoists operated, 4,000 litre hopper
- 1 of Moveable feeding gun for container truck, 4 directions and swing
- 1 of Feeding pipe, Loading cyclone and Loading bellow for Bulk truck
- 1 of High pressure Centrifugal blower 30 .0kw / 40.0 hp
- 1 of Heavy duty air lock granular rotary valves (pellet valve), Stainless steel 304
- 2 of Bag filters for dust controlling system, with 3,500 m³ centrifugal fan
- 1 of Electrical control box, with SEMENS S7 300 PLC with PROFACE touch screen , suitable for full automatic operation and SCADA system requirement

CREATIVE ENGINEERING



1996

Therec Corporation (Establish)

1997

Being Agent of GE Roots Blower

1998

Being Agent of the young industry
First Pneumatic Conveying System at Dutch Mill

2000

First fabrication shop at Bangbon



2008

First Sea Bulk Loading system for SCG Plastic,
Therec Services (Establish)

2011

Fully Automatic Seabulk loading & Big bag
unloading Station for PTT chemical



2012

First separate the company
Therec Engineering & Consulting (TRE)

2013

New Factory TRE Workshop at Rayong



2014

New Silo & Tank factory at Nonthaburi
Therec Processing Maching (TRPM) (Establish)
Therec Technology (Thailand) (TRTT) (Establish)



BRAND VISION

To be the best pneumatic conveying company in Regional

- The Professional designer
- The Innovative designer
- Design with the customer mind
- Customized design for every need
- Your regional business partner

With the high experience and knowledge of our strong engineering design team and the full support from other company in the group, together with the highest continuous attempt, we are now ready to provide the full engineering design and consulting service in the field of pneumatic conveying and bulk material handling system.

The first company in Thailand that call ourselves as;
TRE&C “The Pneumatic Conveying Company”.

Pioneer work and continuous further development.

More than 140 systems installation around in region.

More than 1200 units of the equipment sales and service, blowers, exhauster, rotary valves, diverter valves, lump breakers, bag filters, cyclones and silos.

Clear & Complete engineering process design with the main components of the process coming from a single group, precisely matched for the influences system operation with the full reliable service team.

The 20 Years Old Companies



Therec Group Customer Service Base

FOOD



PLASTIC



MINERAL CHEMICAL AND OTHER



Range of Service from
THEREC
 Service
 Maintenance
 Spare part
 Commissioning
 Training
 System analysis

THEREC ENGINEERING & CONSULTING CO.,LTD.

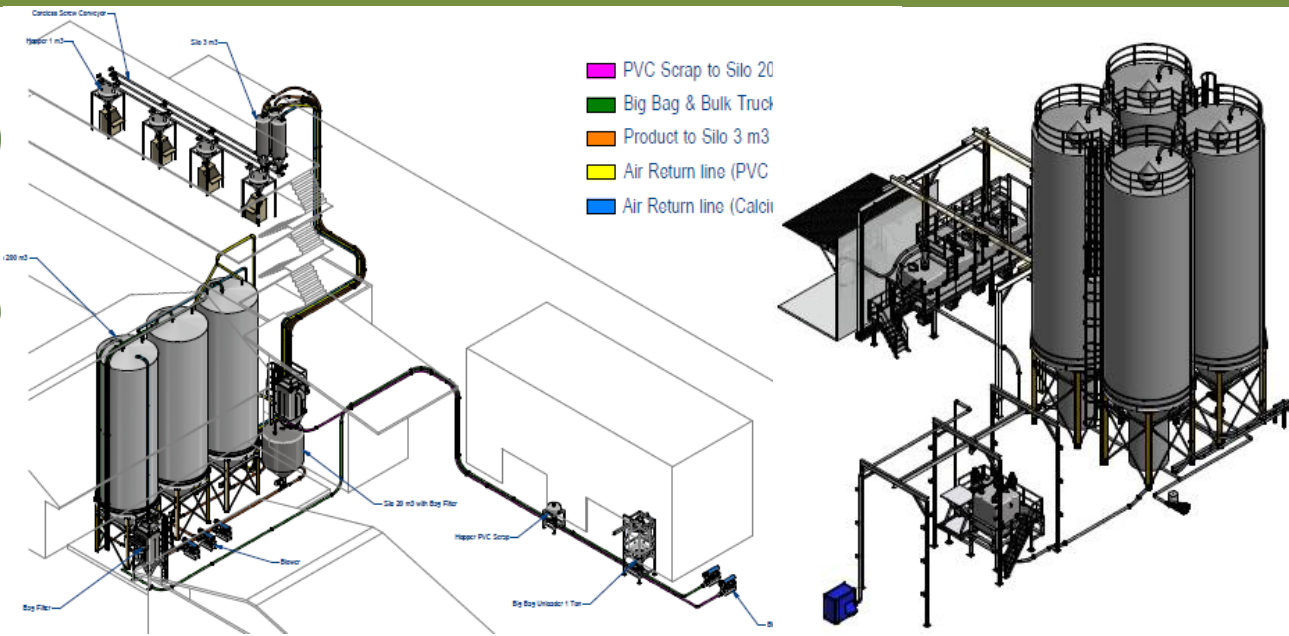

Full Bulk material handling system for powder and bulk processing line / Storage / Loading / Unloading / Weighting / Mixing / Sizes classifying
 Connecting all together by pneumatic conveying system and control.

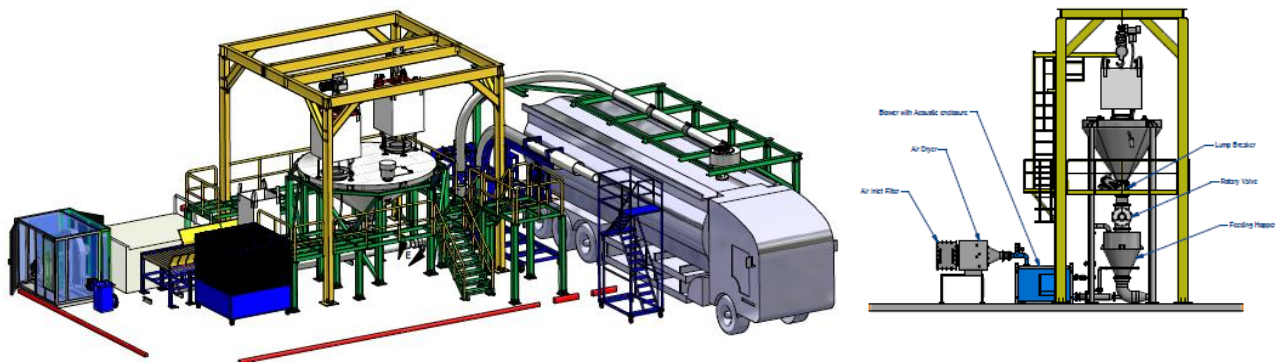

Sea bulk Loader or Bulk Truck loader / Mobile or Fixed Station

